

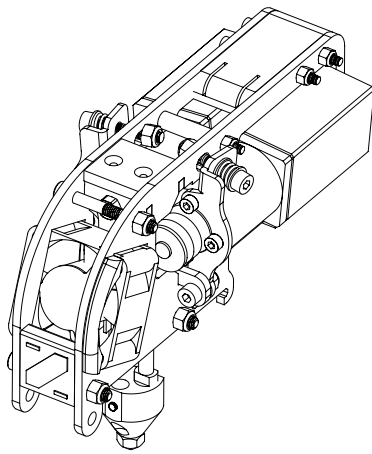

TOOLHEADS

Technical Specification

Dual Extruder Toolhead



SPECIFICATION

Construction:	High-quality aluminium frame with powdered coated casing
Hot End:	Zmorph interchangeable hotends
Temperature control:	1 thermistors
Temperature range:	0 – 250°C
Nozzle:	0.3, 0.4, 0.6 mm
Motor:	Nema 17 stepper motor
Extrusion:	Direct Drive
Work area:	up to 235 x 250 x 165 mm
Extruder dimensions:	57 x 126 x 113 mm
Materials	PLA-PLA, ABS-HIPS, PLA-PVA, ABS-ABS

