

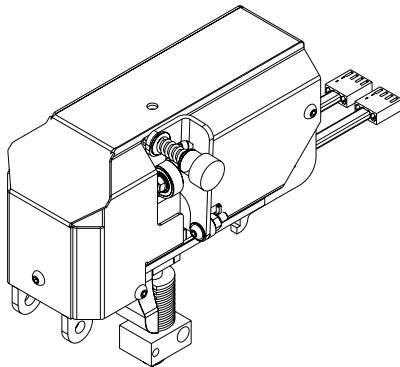

# TOOLHEADS

## Technical Specification

### Single Extruder Toolhead 1.75



#### SPECIFICATION

Construction:	High-quality aluminium frame with powdered coated casing
Hot End:	Zmorph interchangeable hotends
Temperature control:	1 thermistor
Temperature range:	0 – 250°C
Nozzle:	0.3, 0.4, 0.6 mm
Motor:	NEMA 17 stepper drive
Extrusion:	Direct Drive
Work area:	up to 235 x 250 x 165 mm
Extruder dimensions:	57 x 126 x 113 mm
Materials:	PLA, ABS, Nylon, PET-G, ASA, PMMA, TPE, PC, PC-ABS, PP, PVA, HIPS

